

# F85/F86/F87 - Grundpraktikum Optik (Photonics)

S. Manz, R. Folman, L. Feenstra, T. Mandel

February 13, 2012

## 1 Motivation

Solid state light manipulation devices (Photonics) have become a basic tool for scientific research as well as industrial applications. They comprise two distinct advantages:

1. The miniaturization, scalability and accuracy of optical elements and their interface (e.g. for the communication industry)
2. The extraordinary physical effects of some crystals on incident or transmitted light (e.g. frequency doubling, photon down conversion, polarization rotation).

In this lab-course we will address the second issue and give you an introduction to effects which involve polarization, phase and frequency of light in crystals. Following this lab-course, you should have a basic knowledge of these experimental tools.

## 2 Safety



- **Always use the safety glasses when the laser is on.** If the laser light hits your eye, it will immediately cause irreversible damage. When handling with reflecting surfaces, take care you don't produce arbitrary beams: don't wear watches or jewelry. Even if you wear the safety glasses, never look directly into the laser beam! You should also not sit down beside the table.
- **Be careful with high voltage. Never change the set-up while the high voltage power supply is on!**
- **Do not lean on the tables, the dampers (air-cushions) below could burst!**

## 3 Program of the lab-course

The experiments are divided into three blocks, for each experiment we start out with a short introduction to the underlying theory of the effects which you will study followed by the instructions to the experiment. For further reading most textbooks on optics (e.g. Fundamentals of Photonics) should cover all the topics herein. Please be prepared for each experiment on the first day, as there exists only one setup of each experiment and you will need to switch those daily with your fellow students.

## 4 F85: Polarization optics

### 4.1 Theory

Light can be described as an electromagnetic wave. A wave travelling in the  $z$ -direction looks like:

$$E(z, t) = E_0 e^{i(\omega t - kz)}$$

with the wave vector  $k = 2\pi/\lambda$ . The electric field-vector  $\vec{E}$ , the magnetic field-vector  $\vec{B}$  and the direction of propagation  $\hat{e}_z$  create an orthogonal system. Polarization describes the plane in which the electric field or the polarization vector  $\vec{P}$  is oscillating. One can observe  $\vec{P}$  in the plane perpendicular to the direction of propagation and distinguish between three types of polarization:

1. Linear polarization: The electric field  $\vec{E}$  is oscillating along a straight line in the plane of polarization.
2. Elliptic polarization:  $\vec{E}$  describes an ellipse. If the main axes of this ellipse are parallel to the transverse cartesian coordinates, the wave can be written as:

$$\vec{E}_{\pm} = E (a\hat{e}_x \mp ib\hat{e}_y) e^{i(\omega t - kz)}$$

(+ gives clockwise polarization, – counterclockwise. The names are given by observing the wave propagating to the observer, but you might also find the opposite definition in modern books)

3. Circular polarization:  $\vec{E}$  describes a circle, this is a special case of elliptic polarization.

A linear polarized wave can be thought split up in two other linear waves, that are in phase if their addition gives back the original polarization.

$$\vec{E} = \vec{E}_1 + \vec{E}_2$$

It is also possible to obtain a linear polarized wave by adding two counter-rotating circular polarized waves.

Elliptic polarization can be written as a superposition of two linear polarized waves with a phase shift of  $\pi/2$ . The maximum amplitudes of both waves give the main axes of the ellipse in the plane perpendicular to the propagation. For equal amplitudes in both directions one gets circularly polarized light.

In general, natural light, emitted by atoms and thermal light sources, is not polarized. To achieve polarization additional interaction between light and matter or matter-surfaces is needed.

#### 4.1.1 Reflection and Polarization

If dielectric media are interacting with light the molecules are excited to dipole oscillations. When a wave hits a surface between two different media with refractive indices  $n_1$  and  $n_2$  the beam is split in a reflected beam and a refracted one. The refraction angle  $\alpha_2$  is given by Snell's Law:

$$n_1 \sin \alpha_1 = n_2 \sin \alpha_2$$

The angles are taken between the beam and the normal vector to the surface in the plane of incidence, being the plane parallel to the beams and perpendicular to the surface. The reflection angle is  $\alpha_1$ . (Recall that for reflection:  $\alpha_{\text{in}} = \alpha_{\text{out}}$ )

To calculate the amplitudes and intensities of the reflected and refracted beams, one has to separately observe the polarizations parallel or perpendicular to the plane of incidence.

Starting from Maxwells Equations and the resulting surface conditions for  $\vec{D}$ ,  $\vec{E}$ ,  $\vec{H}$  and  $\vec{B}$  one can calculate the amplitude coefficients for the reflection  $r$  and for the transmitted beam  $t$ . These are the square roots of the intensity coefficients  $R$  and  $T$ . For the calculations the reader is referred to the literature.

For a polarization perpendicular to the plane of incidence (also called TE-mode for Transversal-Electric, in German: S-Polarization) the results are:

$$\begin{aligned} r_{TE} &= -\frac{\sin(\alpha_1 - \alpha_2)}{\sin(\alpha_1 + \alpha_2)} \\ t_{TE} &= \frac{2 \sin \alpha_1 \cos \alpha_2}{\sin(\alpha_1 + \alpha_2)} \end{aligned} \quad (1)$$

For the wave polarized parallel to the plane of incidence (TM, Transversal-Magnetic mode, in German: P-Polarization) the reflection and transmission coefficients  $r$  and  $t$  are:

$$\begin{aligned} r_{TM} &= \frac{\tan(\alpha_1 - \alpha_2)}{\tan(\alpha_1 + \alpha_2)} \\ t_{TM} &= \frac{2 \sin \alpha_1 \cos \alpha_2}{\sin(\alpha_1 + \alpha_2) \cos(\alpha_1 - \alpha_2)} \end{aligned}$$

The minus sign in equation 1 shows that for a perpendicular polarization a phase shift of  $\pi$  appears at the surface.

#### 4.1.2 Birefringence (Doppelbrechung)

Linear, isotropic, homogeneous media have the property that for each spatial direction in which light is propagating through it, the index of refraction  $n$ , and thus the velocity of light, is the same. In these media, such as crystals with cubic symmetry, one finds the simple proportionality

$$\vec{D} = \varepsilon \vec{E},$$

where the permittivity  $\varepsilon = n^2$  is a scalar. For anisotropic media  $\varepsilon$  becomes a symmetric tensor  $\varepsilon_{ij}$ . This means that the refractive index is now different for the main axes of the crystal and for different planes of polarization of the light propagating along them.

One has to differentiate between uniaxial and biaxial media. Uniaxial media have one axis that is called optical axis. When light is travelling through the crystal along the optical axis, the index of refraction it encounters is equal for both polarization directions. On the axes perpendicular to the optical axis one finds so-called ordinary and extraordinary indices of refraction.

If one expands  $n$  to three dimensions, meaning for each possible direction of propagation for light in the crystal, one obtains an ellipsoid whose main axes coincide with the axes along which light experiences only a single  $n$ . This ellipsoid, shown in figure 1, is called the indicatrix. (Which axis is the ordinary axis or extraordinary axis depends on the symmetry of the crystal, additional details can be found in the literature.)

To find out what index of refraction a wave experiences, one has to decompose the light in linear polarized waves along two axes  $a$  and  $b$ , and then calculate the indices  $n_a$  and  $n_b$ . Here, this is shown in general. In all practical cases, one would try and decompose the wave along the main axis to simplify the problem, because if light is polarized along an optical axis it ‘sees’ only one index of refraction.

Biaxial crystals show a more complicated indicatrix. In those cases it is usually not an ellipsoid, and the main axes do not coincide with the optical axes.

#### 4.1.3 Wave plates (retardors)

Wave plates are birefringent crystals with a thickness of  $(m + \frac{1}{4})\lambda$  with  $m$  an integer (quarter wave plate) or  $(m + \frac{1}{2})\lambda$  (half-wave plate). They are used to change a certain polarization state of incident light into another state. In this case the expressions ordinary axis and extraordinary axis are not used, instead the axes get their name simply by the value of the refractive index along the axis: fast and slow axis.

Waves travelling along the different optical axes of a *half-wave* plate experience a phase shift of  $\pi$  relative to each other, so that their relative optical retardation is half a wavelength. For linear

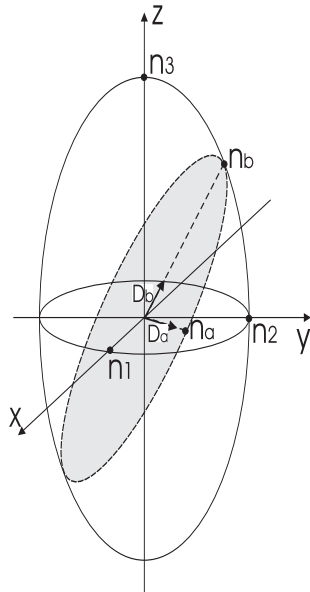

Figure 1: *Indicatrix or index-ellipsoid for an uniaxial medium.*

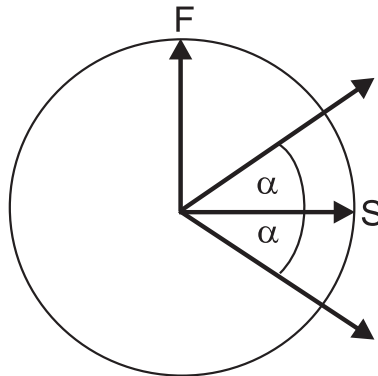

Figure 2: *Rotation of polarization in a half-wave plate.*

polarized light this means that the wave will leave the retarded again linear polarized, but the plane of polarization will be rotated by twice the angle it had to the optical axes when it entered the wave plate, as shown in figure 2. For the special case of  $\alpha = 45^\circ$  the polarization will be rotated by  $90^\circ$ .

*Quarter-wave* plates give a relative phase shift of  $\pi/2$  to waves propagating along the axes. This means that they turn linear polarized light into elliptically polarized light or the other way around. For linear polarized light incident at  $\alpha = 45^\circ$  one obtains circularly polarized light.

## 4.2 Experiments: polarizers and wave plates

In this first part, you should get used to the optical devices you will use throughout the experiments of this lab-course: polarizers, polarizing and non-polarizing beam splitters and wave plates (retarders).

1. Calibrate the polarizers: the markings are only for reference,  $0^\circ$  does not necessarily have to coincide with H/V-polarization!
2. Check if your laser is polarized.
3. Find out how the light which is reflected by or passing through the beam splitters is polarized. How do they work?
4. Build a setup to test the waveplates: Find a position at which the half-waveplates rotate the incident polarization by  $90^\circ$ .
5. Find a position at which the quarter-waveplates produce circular polarized light.
6. Perform the experiments sketched in figures 3 and 4: set up two quarter wave plates behind each other and find out what they do with the polarization of light passing through both plates. Then take the second quarter wave plate and turn it around on its post by  $180^\circ$ , so that the beam traverses the wave plate in the opposite direction. Do this for both combinations of input polarization vs. wave plate orientation shown in the figures. What do you expect? What do you observe? Find an explanation for the effects; what is the difference between both experiments? What is the relevance of these two experiments in relation to a “real” optical experiment?
7. Use a mirror to reflect linearly polarized light in a straight angle ( $> 90^\circ$ ) and measure the polarization of the reflected light. Repeat for a linear polarization perpendicular to that of the previous experiment. Where does the phase shift of  $180^\circ$  occur?
8. Send linear polarized light through two quarter wave plates with their axes at  $45^\circ$  with respect to the plane of polarization and check the output polarization (either case of Fig. 3 or 4). Now change the setup to contain a mirror between the two waveplates which reflects the light at a straight angle ( $> 90^\circ$ ). Check the output polarization again. Explain your observations.
9. Think about what happens to a polarized light beam which passes through a quarter wave plate and is then reflected by a mirror perpendicular to its path so that it passes again through the same wave plate on the way back. How does the outcome depend on the orientation of the wave plate relative to the incident polarization? Design and perform an experiment to prove your theory.
10. Repeat the previous experiment for a half-wave plate.
11. Look into the light of a white lamp through the optical isolator. Do so in both directions of the isolator and explain your observations. How would you have to insert the isolator into the laser beam to see the isolation effect? Test your hypothesis.

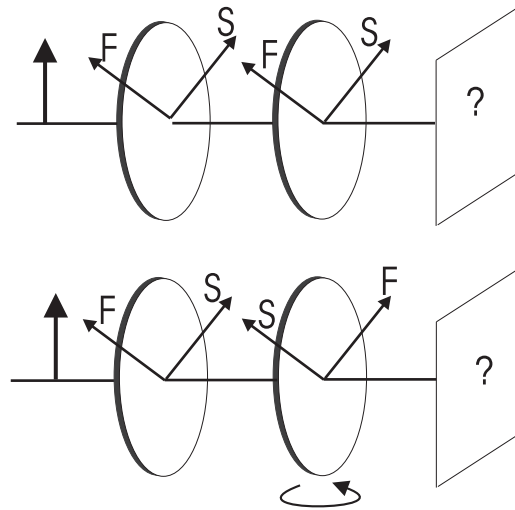

Figure 3: Operations of quarter wave plates with different orientations

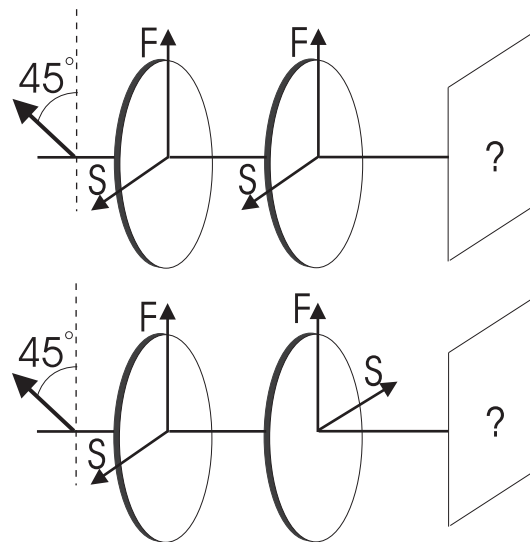

Figure 4: Operations of quarter wave plates with different orientations; here you might have to first rotate the incoming polarization.

## 5 Electro-optic effect

### 5.1 Theory

Some materials change their optical properties when they are brought into an electric field. To use this effect one needs an electro-optic medium, such as some cubic crystals; they called electro-optical modulators (EOM). In that case, the refractive index  $n$  of the medium becomes a function of the applied field  $n = n(E)$ . Since the variations of  $n$  with  $E$  are only small,  $n(E)$  can be expanded in a Taylor series about  $E = 0$ :

$$n(E) = n(0) + \left. \left( \frac{dn}{dE} \right) \right|_{E=0} E + \frac{1}{2} \left. \left( \frac{d^2n}{dE^2} \right) \right|_{E=0} E^2 + \dots$$

Using the coefficients

$$r = \frac{-2}{n^3} \left. \left( \frac{dn}{dE} \right) \right|_{E=0} \quad \text{and} \quad s = \frac{-1}{n^3} \left. \left( \frac{d^2n}{dE^2} \right) \right|_{E=0}$$

and neglecting higher order terms, one can rewrite  $n(E)$  as

$$n(E) = n - \frac{1}{2}rn^3E - \frac{1}{2}sn^3E^2. \quad (2)$$

Typical values for  $r$  are  $10^{-12}$  to  $10^{-10}$  m/V. It is sometimes convenient to use the electric permittivity instead of the refractive index:  $\eta = \varepsilon_0/\varepsilon$ . With

$$\Delta\eta = \left( \frac{d\eta}{dn} \right) \Delta n$$

this yields

$$\eta(E) \approx \eta(0) + rE + sE^2. \quad (3)$$

For  $r \gg s$  we obtain the linear electro-optic effect or Pockels Effect, where the refractive index depends linearly on the applied field. In that case the equations are reduced to  $\eta = \eta_0 + rE$  and

$$n(E) \approx n_0 - \frac{1}{2}rn^3E. \quad (4)$$

Where  $r$  is called the Pockels coefficient.

Similarly, when  $r \ll s$ , we can see from Eq. 3 that we obtain a quadratic dependence of refractive index on the electric field. This is known as the Kerr effect, which will not be studied here.

Since the electro-optic crystals are generally birefringent, the effect of the index of refraction on the light is governed by the relative orientation of the electric field, the crystal axes and the beam path. Thus, the Pockels coefficient  $r$  in Eq. 2 is actually only one entry from a Pockels coefficient-tensor.

$\eta_{ij}$ :

$$\eta_{ij}(E) = \eta_{ij} + \sum_k r_{ijk} E_k = \eta_{ij} + \Delta\eta_{ij}.$$

Since the index ellipsoid, the indicatrix, can now no longer be written with just the principal axes, we have to revert to its general form:

$$\left( \frac{1}{n^2} \right)_1 x^2 + \left( \frac{1}{n^2} \right)_2 y^2 + \left( \frac{1}{n^2} \right)_3 z^2 + 2 \left( \frac{1}{n^2} \right)_4 yz + 2 \left( \frac{1}{n^2} \right)_5 xz + 2 \left( \frac{1}{n^2} \right)_6 xy = 1$$

We thus obtain for the different components:

$$\begin{pmatrix} \Delta(1/n^2)_1 \\ \Delta(1/n^2)_2 \\ \Delta(1/n^2)_3 \\ \Delta(1/n^2)_4 \\ \Delta(1/n^2)_5 \\ \Delta(1/n^2)_6 \end{pmatrix} = \begin{pmatrix} r_{11} & r_{12} & r_{13} \\ r_{21} & r_{22} & r_{23} \\ r_{31} & r_{32} & r_{33} \\ r_{41} & r_{42} & r_{43} \\ r_{51} & r_{52} & r_{53} \\ r_{61} & r_{62} & r_{63} \end{pmatrix} \begin{pmatrix} E_x \\ E_y \\ E_z \end{pmatrix}.$$

The entries in the  $r$  matrix are constrained by the crystal symmetry. The typical magnitudes for the  $r_{ij}$ -coefficients are  $10^{-12}$  m/V. The material used in the practicum is LiNbO<sub>3</sub>. It is a uniaxial crystal with a crystal symmetry  $3m$  and it has indices of refraction  $n_1 = n_2 = n_o, n_3 = n_e$ . The Pockels Coefficients for LiNbO<sub>3</sub> are:

$$\begin{pmatrix} 0 & -r_{22} & r_{13} \\ 0 & r_{22} & r_{13} \\ 0 & 0 & r_{33} \\ 0 & r_{51} & 0 \\ r_{51} & 0 & 0 \\ -r_{22} & 0 & 0 \end{pmatrix} = \begin{pmatrix} 0 & -3,4 & 8,6 \\ 0 & 3,4 & 8,6 \\ 0 & 0 & 30,8 \\ 0 & 28 & 0 \\ 28 & 0 & 0 \\ -3,4 & 0 & 0 \end{pmatrix} \times 10^{-12} \text{ m/V}$$

Where the first matrix shows the general case for crystals with  $3m$  symmetry. However, the Pockels coefficients are very hard to measure reliably and they can be affected strongly by contaminants inside the crystal. Therefore, the above numerical values are only indicative<sup>1</sup>.

For the case of a crystal without an applied field, the indicatrix is given by

$$\frac{1}{n_o^2} x^2 + \frac{1}{n_o^2} y^2 + \frac{1}{n_e^2} z^2 = 1 \quad (5)$$

Depending on the direction of the applied electric field and the direction of the light through the crystal, several distinct situations are possible. Each assembly shows a different behaviour.

One of the most widespread orientations is with the Pockels cell having a longitudinal field, i.e. applied along the extraordinary axis,  $z$ , and the light also travelling along that axis. This means that the light passes through transparent electrodes. In a cell with a transverse field the electric field can be applied along the ordinary axis,  $x$ , and the light then travels along the extraordinary axis, the optical axis  $z$ .

The Pockels cell of this practicum, however, has the electric field applied along the extraordinary axis  $z$ , with the light travelling along one of the ordinary axes, the  $y$ -axis. In this case, the applied electric field  $\vec{E} = E_z$  modifies the indicatrix to:

$$\left(\frac{1}{n_o^2} + r_{13}E_z\right) x^2 + \left(\frac{1}{n_o^2} + r_{13}E_z\right) y^2 + \left(\frac{1}{n_e^2} + r_{33}E_z\right) z^2 = 1$$

This equation can be cast in the form of Eq. 5

$$\frac{1}{n_o'^2(E)} x^2 + \frac{1}{n_o'^2(E)} y^2 + \frac{1}{n_e'^2(E)} z^2 = 1$$

with the modified ordinary and extraordinary indices of refraction  $n_o'(E)$  and  $n_e'(E)$  given by

$$n_o'(E) = \frac{n_o}{\sqrt{1 + r_{13}n_o^3E_z}} \quad \text{and} \quad n_e'(E) = \frac{n_e}{\sqrt{1 + r_{33}n_e^3E_z}}$$

With the approximation  $1/\sqrt{1+x} \approx 1 - \frac{1}{2}x$  for small  $x$ , we can indeed rewrite these indices of refraction in the manner we have seen before in Eqs. 2 and 4:

$$n_o'(E) \approx n_o - \frac{1}{2}r_{13}n_o^3E_z \quad \text{and} \quad n_e'(E) \approx n_e - \frac{1}{2}r_{33}n_e^3E_z \quad (6)$$

### 5.1.1 The Pockels Cell

An electro-optic crystal between two capacitor plates is called an electro-optical modulator. When the crystal exhibits the Pockels effect it is called a Pockels cell.

For light with a wavelength  $\lambda$  travelling through a medium of length  $L$  with an index of refraction  $n$ , the incurred phase in the medium is given by:

$$\Phi = 2\pi nL/\lambda \quad (7)$$

<sup>1</sup>Another source gives for LiNbO<sub>3</sub>:  $r_{13} = 9.6$ ,  $r_{22} = 6.8$ ,  $r_{33} = 30.9$ ,  $r_{51} = 32.6$ . All values in [pm/V]

Since each ordinary and extraordinary axis, has a different index of refraction,  $n_o$  and  $n_e$ , respectively. Light travelling through a birefringent crystal experiences a phase retardation  $\Delta\Phi$  between the two polarizations equal to

$$\Delta\Phi = \frac{2\pi}{\lambda} (n_e - n_o) L \quad (8)$$

With a Pockels cell one can manipulate both  $n_o$  and  $n_e$  by the strength of the electric field, as outlined above. The phase retardation  $\Delta\Phi$  due to a Pockels cell with an applied field  $E$  is thus given by

$$\Delta\Phi(E) = \frac{2\pi}{\lambda} (n'_e(E) - n'_o(E)) L.$$

using the approximations of Eqs. 6 this becomes:

$$\Delta\Phi(E) = \frac{2\pi}{\lambda} (n_e - n_o - \frac{1}{2} (r_{33}n_e^3 - r_{13}n_o^3) E_z) L.$$

With the applied voltage  $V = Ed$  we thus obtain that the retardation is given by Eq. 10:

$$\Delta\Phi(V) = \Phi_0 - \pi \frac{V}{V_\pi} \quad (9)$$

where

$$\Phi_0 = \frac{2\pi}{\lambda} (n_e - n_o) L \quad \text{and} \quad V_\pi = \frac{d}{L} \frac{\lambda}{(r_{33}n_e^3 - r_{13}n_o^3)}$$

are the retardation for  $V = 0$  and the so called half-wave voltage, respectively. At  $V = V_\pi$  the relative phase retardation between the two polarizations is  $\pi$ , causing the Pockels cell to act as a half-wave plate.

### 5.1.2 Transverse Intensity Modulation

One can use a Pockels Cell to modulate the intensity of light. As we have seen, the relative phase retardation between the two polarizations is variable. For intensity modulation, one needs to put the Pockels cell between two crossed polarizers, placed at  $45^\circ$  with respect to the optical axes of the crystal. This set-up has an intensity transmittance  $T = \sin^2(\Phi/2)$ . With equation 9 the transmittance of the device then is a periodic function of  $V$ :

$$T(V) = \sin^2 \left( \frac{\Phi_0}{2} - \frac{\pi}{2} \frac{V}{V_\pi} \right).$$

The device can also be used as a linear modulator if the system is operated in the region near  $T(V) = 1/2$ .

### 5.1.3 Optical Activity and Faraday-Effect

Optically active media rotate the plane of polarization of linear polarized light. As described above, one can treat linear polarization as a superposition of two circular polarized waves with the opposite direction of rotation. In an optically active medium these two circular waves have different phase velocities, and thus the resulting linear polarized wave turns its plane of polarization. Natural optical activity appears in chiral media, such as solutions of dextrose or lactic acid. For these media, the direction of rotation does not depend on the direction of propagation through them; the behaviour is symmetric.

Some media become optically active when an axial magnetic field is applied, which is known as the Faraday effect. In this case the direction of rotation does depend on the direction of propagation, because the B-Field determines a spatial axis and thus breaks symmetry. The angle by which the polarization is rotated depends on the length of the medium  $L$ , on the magnetic field strength  $|\vec{B}|$  and on the so-called Verdet constant  $v$ :

$$\alpha_{\text{rot}} = vL|\vec{B}|.$$

The Verdet constant is a function of the wavelength:

$$v = -\frac{\pi\gamma}{\lambda n}$$

where the magnetogyration coefficient  $\gamma$  is a material constant of the medium.

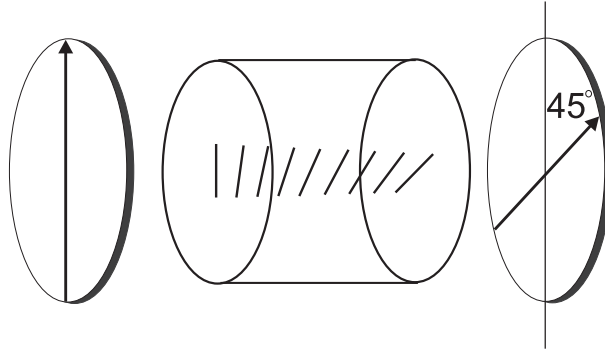

Figure 5: A Faraday isolator or optical diode

The Faraday effect can be used to build an optical isolator. An optical isolator consists of a medium sensitive to the Faraday effect in an axial magnetic field. The set-up is enclosed by two polarizers with an angle of  $45^\circ$  to each other, as shown in figure 5. In an optical isolator the first polarizer defines a plane of linear polarization of the light incident on the optically active medium inside the isolator. The medium rotates the plane of polarization by  $45^\circ$  clockwise, so that the light can pass the rear polarizer.

Light entering the isolator from the other side will first be polarization filtered by the rear polarizer. The plane of polarization is then rotated again by  $45^\circ$  by the medium, this time counter-clockwise. The result is that the polarization is finally rotated perpendicular to the front polarizer, thus it is absorbed. In this way the optical isolator is a one-way device for light, so that is also known as an optical diode. Note that the length of the active medium and the magnetic field determine the amount by which the polarization is rotated, so that optical isolators need to be designed to the wavelength of the used light in order to work properly.

## 5.2 Experiment: Phase shift due to EOM

In this part you will get a feeling of how an electric field (a voltage) can alter the optical properties of a crystal, in the sense that the refractive index of the material is changed. In the first few experiments you will measure the change of the index of refraction directly. In the second set of experiments, you will study the extent of the manipulation by its effect on the polarization state of light transmitted through the crystal.

The electric field is usually applied in the direction of the optical axis of the crystal. There are two possibilities for the direction of the light: parallel or perpendicular to the electric field. In the set-up used in this lab-course, the electric field is along the optical axis and the laser beam is incident perpendicular to the field. Take a closer look at the device; you can clearly see the (copper) electrodes against the crystal. (Don't do this when the laser is on...)

Since the electro-optic effects are only rather small, one needs a high voltage to drive the Pockels cell. The high voltage power supply used to drive the Pockels cell can be controlled by the dials on its front, see figure 6. The preferred way during the practicum, however, is to control the high voltage supply using a control voltage, applied to the analog input on the front panel of the power supply. A periodic input signal will cause an accordingly varying output voltage, e.g. you can sweep the voltage on the Pockels cell using a sawtooth wave form. The toggle-switch determines whether the power supply is controlled by the dial-settings (INT) or by the input voltage (EXT). Note, however, that the output voltage or -current can never exceed the internal control settings (as set with the dials), even when using the analog input: make sure that you set the output range correctly. The output voltage and -current are indicated on the displays of the power supply.



Figure 6: Front view of the high voltage power supply used to drive the Pockels cell.

An input voltage between 0 V and  $\sim +10$  V at the analog input results in an output voltage between 0 V and  $\sim 3$  kV. The voltage applied to the Pockels cell should not exceed 2 kV. A voltage range between 0 V and 1.8 kV produces sufficient data to evaluate.

### 5.2.1 Characterization of the high voltage supply / Familiarization with the set-up

During the experiments you will need to measure the desired optical signal with a photodiode against the voltage on the Pockels cell. The oscilloscope cannot handle the high voltage, but you can measure the control voltage on the analog input of the high voltage supply. Therefore, you need to know the voltage amplification factor of the high voltage power supply. The power supply is built for low frequency modulation, so when actually measuring during the experiments, you will have to use a driving frequency of the function generator  $V_{in}(t)$  below 1 Hz, otherwise the output voltage cannot follow the input signal and you might have another voltage on the Pockels cell than you think. The signal generator does not display such low frequencies correctly, use the oscilloscope as a reference.

#### To do:

1. Measure the amplification factor of the high voltage amplifier / power supply.

Optical wavelength	$\lambda = 632.8 \text{ nm}$
Pockels cell material	$\text{LiNbO}_3$
Electrode separation	$d = 2 \text{ mm}$
Crystal length	$L = 20 \text{ mm}$
Indices of refraction	$n_o = 2.286$
at $\lambda = 633 \text{ nm}$	$n_e = 2.200$

Table 1: *Specifications of the used Pockels cell set-up*

- Switch off the high voltage power supply. Leave the power supply connected to the filter-box, but disconnect the Pockels cell from the filter-box in order not to harm the cell inadvertently. The filter-box remains connected to discharge the high-voltage output and to let you check whether the current-settings of the high voltage power supply are not too low. To disconnect the cell from the filter-box: disconnect the cables **on the filter-box side** so that you can measure the entire set-up without high voltage risks, such as short-circuiting etc. due to having open cables next to a steel table.
  - First check the signal of the function generator on an oscilloscope and make sure it is positive. Next, connect the function generator also to the analog input of the high voltage power supply. Set the toggle switch to EXT.
  - Since the oscilloscope cannot take more than 300 V, you cannot measure the high voltage signal directly; you will have to rely on the indicators on the display of the power supply.
  - The function generator can generate three different wave forms (sine wave, triangle wave and square wave / block pulse) which each can be varied in frequency, amplitude and offset with the appropriate buttons. Use the lowest frequency the function generator can supply and the “measure : average” function of the oscilloscope to record sufficient data points.
2. Evaluate your measurements in your log book (Is the amplification linear? Can you use your data points or do they scatter too much? What limits should you set on the input voltage the not to harm the Pockels cell? etc.) before proceeding with the next step.
  3. Set up the function generator and the oscilloscope for the following series of experiments
    - Connect the function-generator to the oscilloscope and display a full period on the screen with a frequency of  $\sim 0.6 - 1 \text{ Hz}$ .
    - Adjust the amplitude and offset of the function generator correctly, so that the Pockels cell will survive ( $V_{\text{output}} = 0 - 1800 \text{ V}$ ).
    - Hint: make your adjustments of the function generator at a high frequency ( $\sim \text{kHz}$ ) to have an accurate feedback on your changes. Don't forget to switch back to low frequencies when actually measuring.

### 5.2.2 Mach-Zehnder interferometer

To determine whether light undergoes a phase shift and to which extent, one needs a set-up that compares the phase of the original laser beam with the phase of the light transmitted through the Pockels cell. Here, a Mach-Zehnder interferometer is useful. A Mach-Zehnder interferometer consists of two non-polarizing (**Why?**) beam splitters and two (totally reflecting) mirrors, see Fig. 7. Since the two beams travel independently and spatially separated through the interferometer, phase shifts can be introduced to a single beam, without affecting the other one. The result of the phase shift can be determined by the intensity output. Due to the two separated beams, a Mach-Zehnder Interferometer is difficult to align, but its high sensitivity to phase shifts makes it useful for various applications.

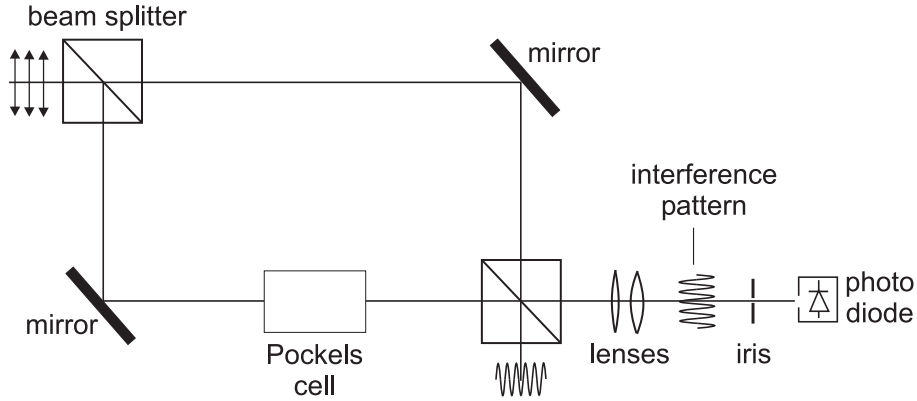

Figure 7: Set-up for phase modulation within a Mach-Zehnder Interferometer

The intensity at one output port of the interferometer is  $I_{\text{out}}$  is related to the incident intensity  $I_{\text{in}}$  by

$$I_{\text{out}} = \frac{1}{2}I_{\text{in}} + \frac{1}{2}I_{\text{in}} \cos \phi = \frac{1}{2}I_{\text{in}} (1 + \cos \phi)$$

where  $\phi = \phi_1 - \phi_2$  is the phase difference between the light beams passing through the branches 1 and 2. For the transmittance we have:

$$T = \frac{I_{\text{out}}}{I_{\text{in}}} = \frac{1}{2} (1 + \cos \phi) = \cos^2 \frac{\phi}{2}$$

If the Pockels cell is placed in branch 1, we get

$$\phi_1(V) = (\phi_1)_{\text{empty}} + \Phi(V) = (\phi_1)_0 + \left( \Phi_0 - \pi \frac{V}{U_\pi} \right) = (\phi_1)'_0 - \pi \frac{V}{U_\pi}.$$

Yielding the following relation between  $\phi$  and the applied voltage:

$$\phi(V) = \phi_0 - \pi \frac{V}{U_\pi}$$

where the constant  $\phi_0 = (\phi_1 - \phi_2)_0$  includes the path difference between the two branches. (In this set-up  $\phi_0 = 0$ , but in other books you might find other types of Mach Zehnder Interferometers.) We finally obtain for the transmittance:

$$T(V) = \cos^2 \left( \frac{\phi_0}{2} - \frac{\pi V}{2 U_\pi} \right)$$

**To do:**

1. Determine the directions of the optical axes of the Pockels cell (see also chapter 4.2 and table 1).
2. Construct a Mach-Zehnder Interferometer with the electro-optical modulator in one arm.
  - Set up the first beam splitter and the mirrors. It is recommended to have the beams all lying in the same, horizontal, plane. If this is impossible, the original laser beam might not be parallel to the optical table, or the first beam splitter is tilted. The former can be corrected by using a so-called “dog leg” before entering the interferometer: use two mirrors to create a Z-shaped laser beam path, which allows you to align the laser beam in every possible direction. The latter problem can be corrected with the screws of the mounting of the beam splitting cube.

- Next, adjust the mirrors so that both laser beams cross (again, preferably in the same horizontal plane) at a certain point, preferably with the beam paths perpendicular to each other.
  - Insert the second beam splitter. The point where the two beams cross has to be at the beam splitting interface within the cube. You will have a good approximation of this when the beams enter the cube at the same position (in the center of the surface, ideally) and/or if they seem to overlap directly after the cube in both exit ports of the interferometer.
  - Now, adjust the second beam splitter so that both beams in at least one exit port overlap. At a proper alignment you will be rewarded with an interference pattern in the exit beams. It is helpful to use a lens to widen up the beam, so that you can detect the interference pattern more easily.
  - To measure the phase difference, adjust the interferometer so that you see  $\sim 3 - 5$  interference maxima in the laser beam. Widen up the interference pattern with a lens so that the fringe spacing is approx. 2 mm at the position of the photodiode and project only the maximum of a single fringe (**Why?**) onto the photodiode (use an iris).
  - In general: Keep in mind that you can only influence *reflected* beams, not those transmitted by beam splitters. Also note that a large interferometer is more sensitive to noise (vibrations from walking around etc.).
3. Set up the measurement
    - Make sure you have determined the correct position/orientation of the Pockels cell with respect to the polarization of the incident light.
    - Make sure that you do not saturate the photodiode ( $V_{\text{out}} < 3 \text{ V}$ ).
    - The oscilloscope is connected to the lab computer. The recorded data can be read by a LabVIEW program, which can display the graphs and print them on the printer in the lab. You can also store the data in a file for analysis at home (the lab computer has an Internet connection so you can send the files per e-mail)
  4. Measure the output intensity as a function of the applied voltage for both crystal axes.
  5. Compare the result for both  $\pm \sim 90^\circ$  axes. What effect does a rotation of  $180^\circ$  of the Pockels cell have?

**Evaluation:**

1. Determine the half-wave voltage  $U_\pi$  for both crystal axes.
2. Determine the Pockels coefficients  $r_{13}$  and  $r_{33}$ .

Just for fun: connect the loudspeaker to the photodiode and tap lightly on the table next to the interferometer; can you explain what you hear and what you see in the interference pattern?

### 5.3 Polarization Manipulation / Intensity Modulation

The Pockels cell is a birefringent crystal, with both the fast axis and the slow axis voltage dependent, the device acts as an arbitrary-wave retarder. To understand this fact we have to observe the phase difference between both perpendicular planes of linear polarization. In this case we again find that the phase difference incurred by each linear polarization is given by Eq. ??, with the appropriate values of  $r$  and  $n$ . As explained in Chap. 5.1, this phase difference is given by

$$\Delta\Phi(V) = \Phi_0 - \pi \frac{V}{V_\pi} \tag{10}$$

where

$$\Phi_0 = \frac{2\pi}{\lambda} (n_e - n_o) L$$

and

$$V_\pi = \frac{d}{L} \frac{\lambda}{(r_{33}n_e^3 - r_{13}n_o^3)} \quad (11)$$

are the retardation for  $V = 0$  and the so called half-wave voltage, respectively. At  $V = V_\pi$  the relative phase retardation between the two polarizations is  $\pi$ , causing the Pockels cell to act as a half-wave plate.

The effect of the Pockels cell on the polarization state of transmitted light can be studied in a manner equivalent to the experiments of Chap. 4.2. You can measure the intensity of light transmitted by a pair of crossed polarizers with the Pockels cell in between. Here, you will measure the intensity behind the analyzing polarizer with a photodiode as a function of the high voltage applied to the Pockels cell.

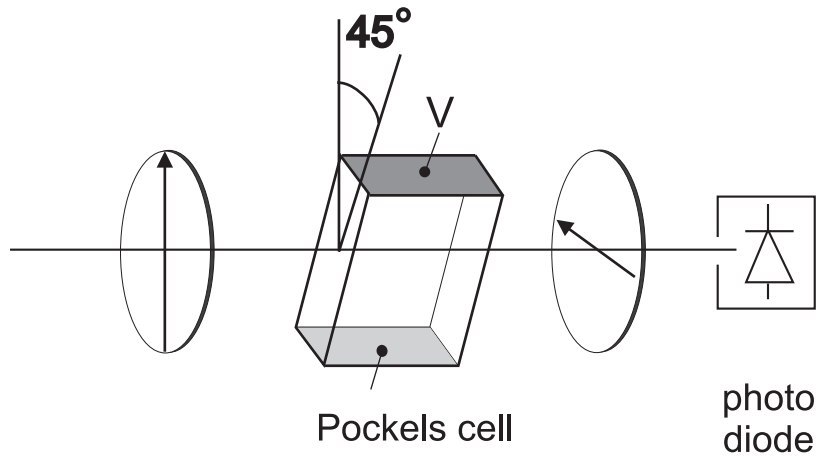

Figure 8: *Experimental Set-up for Transverse Amplitude Modulation*

**To do:**

1. Construct the set-up outlined in Fig. 8, with the Pockels cell placed between two crossed polarizers with their transmission axes at an angle of  $45^\circ$  to the optical axis of the crystal. **Why does the Pockels cell need to be at  $45^\circ$ ?** Make sure you have determined the correct orientation of the Pockels cell. Make sure you will not saturate the photodiode.
2. Measure the transmitted power on the photodiode as a function of the applied high voltage on the Pockels cell for both orientations  $\pm 45^\circ$ . Record your data on the computer.

**Evaluation:**

1. Use the plots of transmitted power vs. applied voltage for both orientations  $\pm 45^\circ$  to determine the half-wave voltage  $V_\pi$ .
2. What is the difference between the  $\pm 45^\circ$  cases?
3. If the first intensity maximum is not at 0 V: why is that?
4. Calculate  $V_\pi^{\text{calc}}$  for the Pockels cell, using Eq. 11 and your previously measured values of  $r_{13}$  and  $r_{33}$ .

5. Calculate  $V_{\pi}^{\text{calc}'}$  directly from your measured  $(U_{\pi})_e$  and  $(U_{\pi})_o$ .
6. Compare your calculated and measured results to the specifications:  $V_{\pi} \approx 380$  V.

### 5.3.1 Linear Amplitude Modulation

Consider the set-up of your previous experiment, see Fig. 8. For a certain range of voltages, the intensity output of the setup shows an almost linear dependency with the applied voltage. This means that it is possible to linearly modulate the intensity of the transmitted light and thus transmit an arbitrary signal optically. For this, one has to modulate the applied voltage to the Pockels cell with the desired signal. For maximum signal amplitude modulation, you have to set up the Pockels cell at this particular voltage, then also a low-voltage signal can suffice to give an appreciable intensity variation.

**What is the necessary high voltage offset? At this voltage, the Pockels cell acts equivalently to another optical element. Which element is that?**

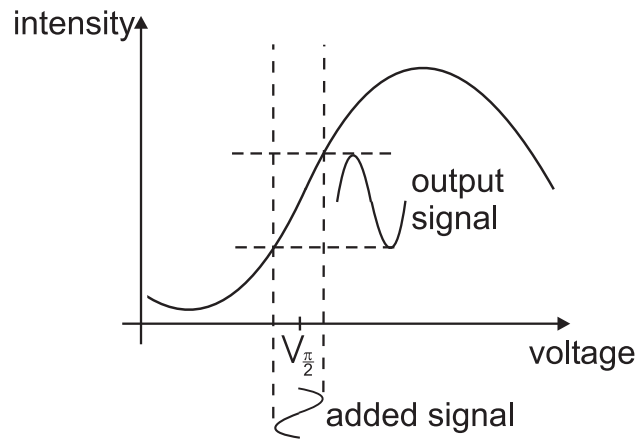

Figure 9: Voltage range for Linear Amplitude Modulation

To test the possibility of linear amplitude modulation, and to get an idea of the possible response-time of the Pockels cell, use the set-up of the previous experiment, see Fig. 8. Use the 'internal' setting of the high voltage supply to apply a DC offset voltage to the Pockels cell. Use the function generator for a high frequency ( $\sim$  kHz) signal. Add both signals via the filter-box in the set-up; now the Pockels cell will 'see' both voltage signals. Compare the function generator / input signal with the photodiode signal on the oscilloscope; optimize the amplitude response of the photodiode (in other words: optimize the modulation efficiency of your set-up) by varying the offset voltage for the Pockels cell.

#### Evaluation:

1. What happens with the transmitted signal at different offset voltages? Why is that?
2. At which points can you improve the signal-to-noise ratio? e.g. should you amplify the laser power, the high voltage, the modulation amplitude and/or other parts of the set-up?

Now replace the signal of the function generator with a radio signal and connect the output to a loudspeaker instead of to the oscilloscope. First check with the loudspeaker whether the radio (web-radio from the lab-computer) is turned on and tuned to a radio station. Connect the photodiode to the loudspeaker and listen to the effect of changing the offset voltage on the Pockels cell and varying the orientation of the last polarizer.

**Evaluation:**

1. Describe and explain your observations.

**Note**

The fast response of electro-optic modulators to electric field changes is used in LCD-displays and similar devices. Electric fields then switch the orientation of long polymer chains between crossed polarizers to vary the light transmission through the pixel.

## 6 Acousto-Optic Effect

### 6.1 Theory

The refractive index of a crystal can be changed by a sound wave. Since a sound wave is a periodic density modulation, the refractive index itself will also vary periodically. The spatial period of the modulation is the sound wavelength,  $\lambda_s$ . A sound wave in a crystal with initial refractive index  $n_0$  can be described by:

$$n(x, t) = n - \Delta n_0 \cos\left(\omega t - \frac{2\pi}{\lambda_s} x\right)$$

$\Delta n_0$  is the amplitude which is given by the photo-elastic constant  $p$  and the amplitude of the strain (relative displacement)  $s_0$ :

$$\Delta n_0 = \frac{1}{2} p n^3 s_0$$

This is also proportional to the acoustic intensity.

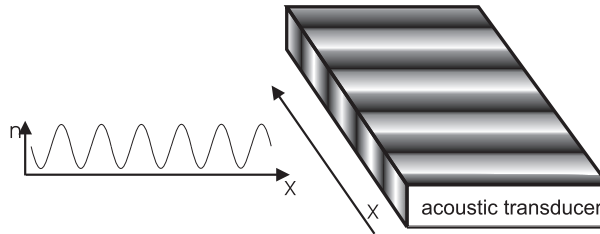

Figure 10: *Modulation of the refractive index by a sound wave*

The simplest form of interaction between a laser beam and a sound wave is the so called Bragg diffraction, which appears for long interaction lengths, i.e. wide crystals. Here, the laser beam is reflected partially or totally off planes of equal density in the crystal.

For a short interaction length, i.e. a thin crystal or better a thin sound beam, the **Debye-Sears effect** appears. Here the sound beam acts as a phase grating: since the laser beam has a certain width, the initial plane wavefront is deformed by travelling through the sound beam. The parts of the light beam travelling through denser areas of the crystal experience a higher index of refraction, than other parts. This means that the parts of the former plane wavefront incur a phase shift relative to each other. In this sense the system is analogous to a grating: in the near field the final wavefront leaving the crystal is bent, in the far field it gives rise to an interference pattern with several higher orders, as shown in Figure 11.

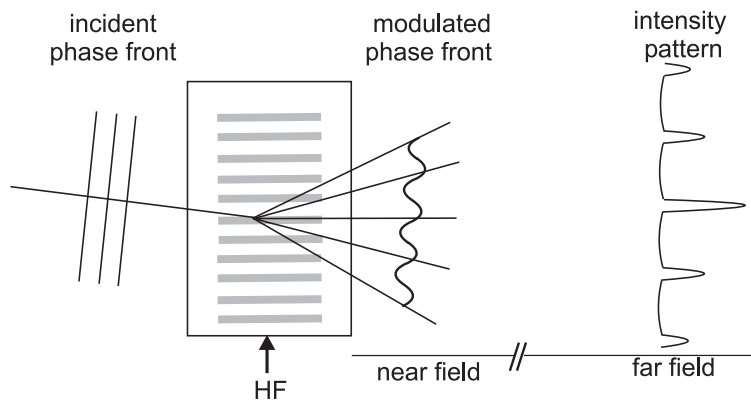

Figure 11: *Deformation of a plane wavefront by a sound wave travelling through a thin crystal*

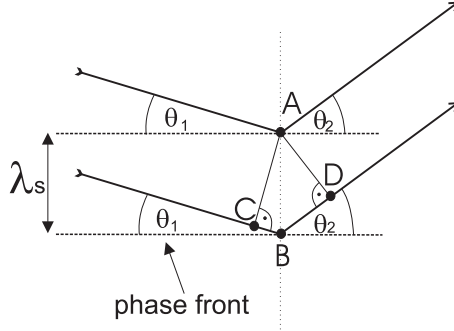

Figure 12: One can observe a maximum in the far field if light reflected from A and B interferes constructively.

Since the light interacts with a moving sound wave, the diffracted light is Doppler-shifted. This means that the light in higher orders has a higher or lower frequency, depending on the number of the diffraction order. To calculate the diffraction angles, have a look at figure 12. Light reflected from A and B interferes constructively, if (Eq. 15)

$$\sin \theta_1 + \sin \theta_2 = \frac{m\lambda}{\lambda_s} \quad (12)$$

where  $\theta_1$  is the incident angle of the light,  $\theta_2$  is the diffraction angle and  $\lambda$  and  $\lambda_s$  are the wavelengths of the light and the sound wave respectively. The Bragg condition for constructive interference is fulfilled when

$$\sin \theta_B = \frac{1}{2} \frac{m\lambda}{\lambda_s}$$

with  $\theta_B$  the Bragg-angle. In the case of a thin grating, as we have here, we have  $\theta_1 + \theta_2 = 2\theta_B$ , and for a thick grating the more rigorous  $\theta_1 = \theta_2 = \theta_B$  holds.

Since the sound wave, i.e. the grating, is moving, one should consider the effects of the Doppler shift of a wave reflected on a moving mirror, which is given by

$$\Delta\omega = 2\omega \frac{v}{c}$$

with  $v$  the velocity of the mirror. For the case of the grating in an AOM we have  $v = v_s \sin \theta_1$  (see Fig. 12) so that the resonating frequency inside the crystal (the frequency showing constructive interference on the grating) is the one Doppler shifted to:

$$\omega_{\text{res}} = \omega + 2\omega \frac{v_s \sin \theta_1}{c},$$

where  $v_s$  is the sound velocity in the crystal. Using again the Bragg condition  $2\lambda_s \sin \theta_1 = \lambda$  one sees that

$$\Delta\omega = 2\pi \frac{v_s}{\lambda_s} = \omega_s$$

Thus each diffraction spot has a different optical frequency, given by:

$$\omega_{\text{out}} = \omega_{\text{in}} + m\Delta\omega = \omega_{\text{in}} + m\omega_s$$

or equivalently:

$$\nu_{\text{out}} = \nu_{\text{in}} + m\Delta\nu = \nu_{\text{in}} + m\nu_s$$

### 6.1.1 Photon-phonon model

Another way to visualize the effect of an AOM on a light beam is to regard the system as two scattering quasi-particles: a photon and a phonon. Both quasi-particles carry a momentum of  $\hbar\vec{k}_l$  and  $\hbar\vec{k}_s$ , respectively, with  $\vec{k}_i$  the wave vector of the interacting waves. Momentum conservation dictates that

$$\vec{k}_{\text{out}} = \vec{k}_{\text{in}} \pm m\vec{k}_s, \quad (13)$$

and energy conservation dictates

$$\nu_{\text{out}} = \nu_{\text{in}} \pm m\nu_s. \quad (14)$$

with  $m$  the diffraction order, i.e. the number of phonons the light wave interacted with. Eqs. 13 and 14 show that the outgoing light wave has undergone a change in both frequency and direction with respect to the incident light, proportional to the diffraction order and the used sound frequency. Light beams diffracted by the density variations caused by the sound wave interfere constructively when

$$\sin \theta_1 + \sin \theta_2 = \frac{m\lambda}{\lambda_s}, \quad (15)$$

where  $\theta_1$  is the angle under which the light enters the crystal and  $\theta_2$  is the diffraction angle. The dependency of the diffraction efficiency of the AOM, meaning the power transmitted to the first order maximum, relative to the power in the un-diffracted beam, is given by:

$$R = \sin^2 \left( \frac{\pi L}{\lambda \cos \theta_B} \sqrt{\frac{M_2 I_s}{2}} \right) \quad (16)$$

where  $L$  is the interaction length of the light beam with the sound wave,  $\lambda$  is the optical wavelength,  $\theta_B$  is the Bragg angle,  $I_s$  is the intensity of the sound wave.  $M_2$  is a *figure of merit* for the used acousto-optic material<sup>2</sup>, in the case of the used TeO<sub>2</sub> the constant is  $M_2 = 34.5 \times 10^{-15} \text{ s}^3 \text{ kg}^{-1}$ . For low sound-input power, the behaviour is approximately linear. For higher sound-input powers the power behaves as a squared sine function, as shown in Figure 13.

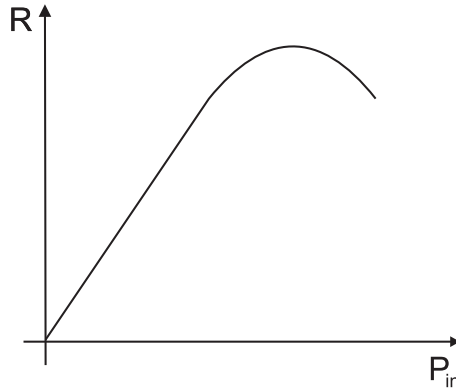

Figure 13: Relative power transmitted to the first diffraction order as a function of sound-power

<sup>2</sup> $M_2 = n_0^6 p^2 / \rho v_s^3$ , with  $n_0$  the refractive index,  $p$  the photo-elastic constant,  $\rho$  the material density and  $v_s$  the sound velocity in the crystal.

## 6.2 Experiments: Acousto-Optic Modulation

In this part you will learn how a light beam can interact with a sound beam.

There are two possibilities for the interaction: the diffraction of a light beam by the Debye-Sears-effect or by Bragg-diffraction. In this set-up one can observe the Debye-Sears-effect (for Bragg-diffraction: see attachment). If the crystal, or better the sound-beam, is thin enough, it behaves as a phase grating with period equal to the wavelength of the used sound wave,  $\lambda_s$ .

The sound wave is not coupled into the crystal by a simple loudspeaker, but by an acoustic transducer using the Piezo-electric effect: A high-frequency signal ( $\sim 110$  MHz) is applied to one end of the crystal. The piezo-electric crystal is compressed and expanded by the signal thus being compacted and rarefied. This density variation which is now moving through the crystal is the sound wave.

The signals, with a necessary power of  $\sim 1$  W, are produced by the AOM-drivers, which you will find above the tables. The heart of these AOM-drivers is a VCO (Voltage Controlled Oscillator), which produces an oscillating signal with a frequency proportional to the input voltage  $V_{in}$ . Figure 14 shows the front of the driver: when the toggle switch is set to INTERN, the VCO gives out its internally specified frequency<sup>3</sup> When the toggle switch is set to EXTERN, the input voltage  $V_{in}$  can be directly applied to the BNC-connector below.

The signal amplitude is controlled similarly: when the toggle switch is set to INTERN, the driver gives out its internally specified amplitude<sup>4</sup> When the toggle switch is set to EXTERN, the signal amplitude can be controlled by a voltage applied to the BNC-connector below.

The output (HF-OUTPUT) is transmitted directly to the crystal. **The output has to be connected at all times! Otherwise, the entire power would be reflected into the driver, which would kill it immediately! (Reflection of waves on an open end.)**

To measure the frequency of the signal, use the MONITOR-output. The signal can be measured with an oscilloscope or with a frequency counter.

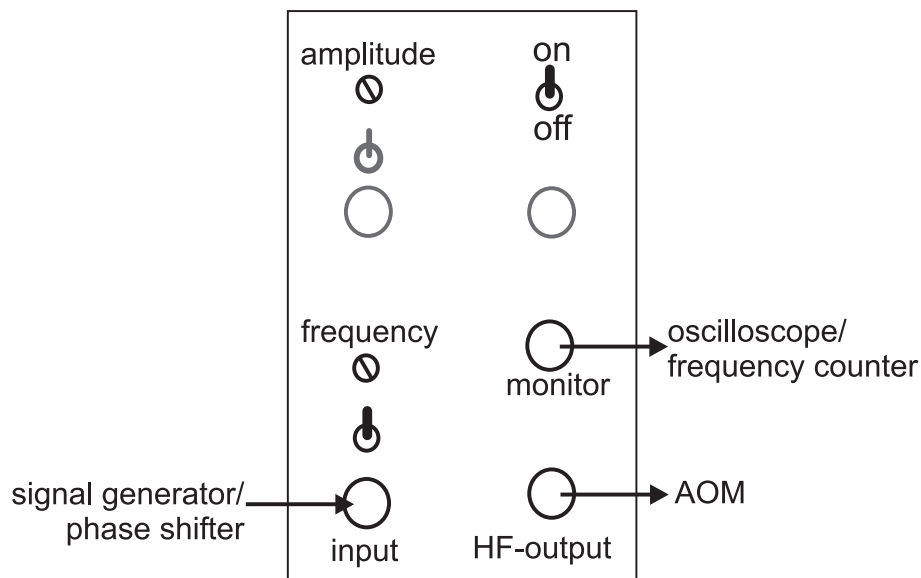

Figure 14: *Front panel of an AOM driver*

<sup>3</sup>in principle one can change the VCO-input voltage - and thus the generated frequency - by turning the screw under FREQUENCY. **This should only be done by the tutor!**

<sup>4</sup>in principle one can change the default signal amplitude by turning the screw under AMPLITUDE. **This should only be done by the tutor!**

Optical wavelength	$\lambda = 632.8 \text{ nm}$
AOM material	$\text{TeO}_2$
Crystal length	$L = 20 \text{ mm}$
Crystal height	$h = 3 \text{ mm}$
Indices of refraction	$n_o = 2.261$
at $\lambda = 633 \text{ nm}$	$n_e = 2.142$
Sound velocity in the crystal	$v_s = 4260 \text{ m/s}$

Table 2: Specifications of the used AOM set-up

### 6.2.1 Experiments with a single AOM

In the following experiments, construct your set-up according to figure 15.

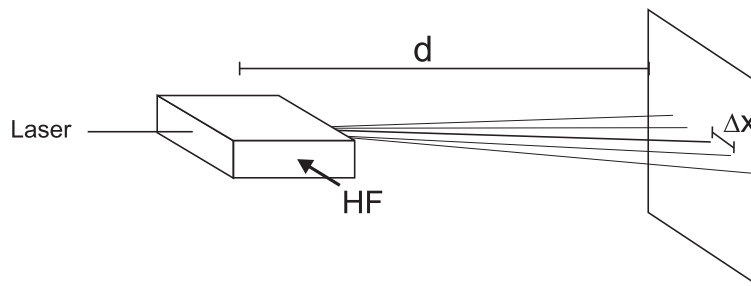

Figure 15: The angles can be determined by measuring the distance between the first and the zero order maximum.

#### To do:

1. Adjust the AOM so that the amplitude of the diffraction pattern is approximately symmetric in both  $\pm 1$  orders. Measure the diffraction angles of the first and second order maxima for different frequencies, see Fig. 15. This AOM can work at  $110 \pm 25 \text{ MHz}$ , use a suitable stepsize. You can increase the precision of your result when you reduce the relative errors in your measurement; construct your set-up accordingly.
2. Measure the power in one first order maximum, relative to the power in the undiffracted beam, vs. the *frequency* of the sound wave in the same range and stepsize as before. Make sure beforehand that the photodiode is not saturated and reduce laser power if necessary (e.g. using a polarizer and PBS to couple power out of the main beam.)
3. Optimize the power in the first order maximum. Determine the relation between the power in the first order maximum, relative to the power in the un-diffracted beam vs. the *amplitude* of the sound wave, see also Fig. 13. Make sure beforehand that the photodiode is not saturated, as before.

#### Evaluation:

1. Plot and evaluate the data of your measurements.
2. Determine the sound velocity in the AOM-crystal.
3. What is the wavelength of the sound in the crystal? On how many grating periods does the light diffract?
4. Determine the sound power in the crystal at the optimum deflection efficiency.
5. Which elements in the AOM-set-up determine the optimum working frequency?

### 6.2.2 Two perpendicular AOMs

For the next series of experiments, adjust two AOMs perpendicular to each other, so that the laser beam traverses both AOMs, see Fig. 16. Put both AOMs close ( $\lesssim 1$  cm) to each other.

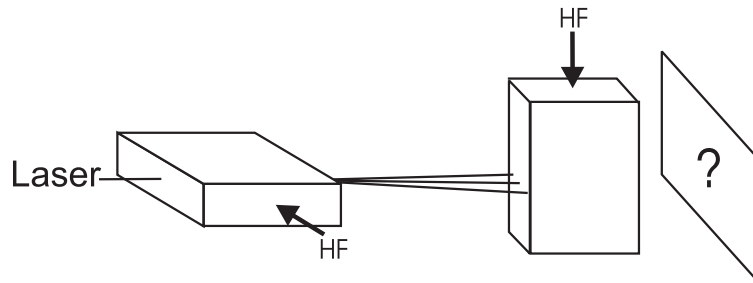

Figure 16: A set-up with two AOMs perpendicular to each other

On the optical table, you will find a box with one input-port and two output-ports. This is the so-called phase-shifting box. The phase-shifting box takes a single input signal which it transmits to both output ports. When the incoming signal is periodic, the box allows you to delay the output on one output port, thus to change the relative phase between both output signals. The box also allows you to add a voltage offset to each output signal independently.

#### To do / evaluation:

Connect each output of the phase-shifting box to the frequency-control inputs of one AOM driver. Do so via the oscilloscope, so that you can monitor that the applied voltages remain inside the allowed boundaries.

1. What diffraction pattern of the laser do you expect? What do you get?
2. What happens to the diffraction pattern when you change one or both of the offset voltages? Why is that?

Now connect the function generator to the phase shifting box input. It may be enlightening to switch the oscilloscope between YT-display (regular format) and the XY-mode<sup>5</sup> regularly during the experiments. **Note that the signal offset-value is not shown when the oscilloscope is in XY-mode:** make sure you stay within the limits.

#### To do / evaluation:

1. What happens to the diffraction pattern when you modulate the sound *amplitudes* at a modulation frequency of  $\sim 1 - 100$  Hz? And above? And for different input wave forms?
2. What happens to the diffraction pattern when you modulate the sound *frequencies* of both AOMs simultaneously at a modulation frequency of  $\sim 1-100$  Hz? And above? And for different input wave forms (sine, triangle, block)?
3. Observe and explain the diffraction patterns at a relative phase difference between both output channels of  $0^\circ$ ,  $90^\circ$ , and  $180^\circ$ .
4. Compare the diffraction spots of the zeroth and first rows and columns respectively for each relative phase difference. How are the patterns connected to each other? Can you draw a circle with the  $(\pm 1, \pm 1)$  or  $(\pm 1, \pm 2)$  order? And with the  $(\pm 2, \pm 2)$  order?

<sup>5</sup>Here channel 1 is displayed as X, channel 2 as Y on the oscilloscope display.

5. How do these effects relate to the polarization state of light, in the sense of two perpendicular oscillating fields? Evaluate your observations in this part of the practicum in relation to what you learned in the first part of the practicum.
6. The phase-shifting box and its effect on the pattern of the  $(\pm 1, \pm 1)$  order can be seen as the analogue to another part of the practicum: which part?

Connect each AOM to a different function generator (again via the oscilloscope). In this way, you can observe the effects of having different frequencies and varying relative phases between both modulation signals. The phase-shifting box is unnecessary here. (You might have to borrow the second frequency generator from your colleagues for a couple of minutes).

**To do / evaluation:**

1. Try to modulate the sound frequency of one AOM *exactly* twice, three times, ..., as fast as the other one. What happens when the modulation is not *exactly*  $n$  times the other? How can you tell when the phase difference is stable?
2. Can you now draw a circle with the  $(\pm 1, \pm 2)$  order? And with the  $(\pm 2, \pm 2)$  order?
3. How do these effects relate to the polarization state of light in the sense of two perpendicular oscillating fields?
4. What is the difference between a laser and 'regular' light (e.g. from a light bulb)?
5. What do the coherence time and -length of a laser mean?

**Note**

AOMs are used for several purposes. Usually the zeroth order, the un-diffracted beam, is blocked and only the first order is used. With an AOM one can realise a fast switch for optical signals, since the switching time is determined by the intensity slope of the sound pulse and its velocity inside the crystal. Switching times of  $\sim 10$  ns can be reached.

In atom-optical or spectroscopic experiments the frequency shift of the orders is used: the wavelength (frequency) of a laser is fixed to some convenient value near the frequency desired for the experiment. AOMs then allow to generate several different frequencies for the experiments all derived from the same center frequency delivered by the single laser, rather than to have to build several lasers.

Other purposes use the scanning function when sweeping the input frequency: e.g. laser shows. But the most prominent use is the use in laser-printers: AOMs deflect a laser beam across an electrically charged drum and induce a small, local discharge. At these spots toner particles will stick, which can then be stamped onto the paper. In this case two-dimensional deflection is performed by having two piezo-elements on different faces of a single crystal, rather than having two independent AOMs.